

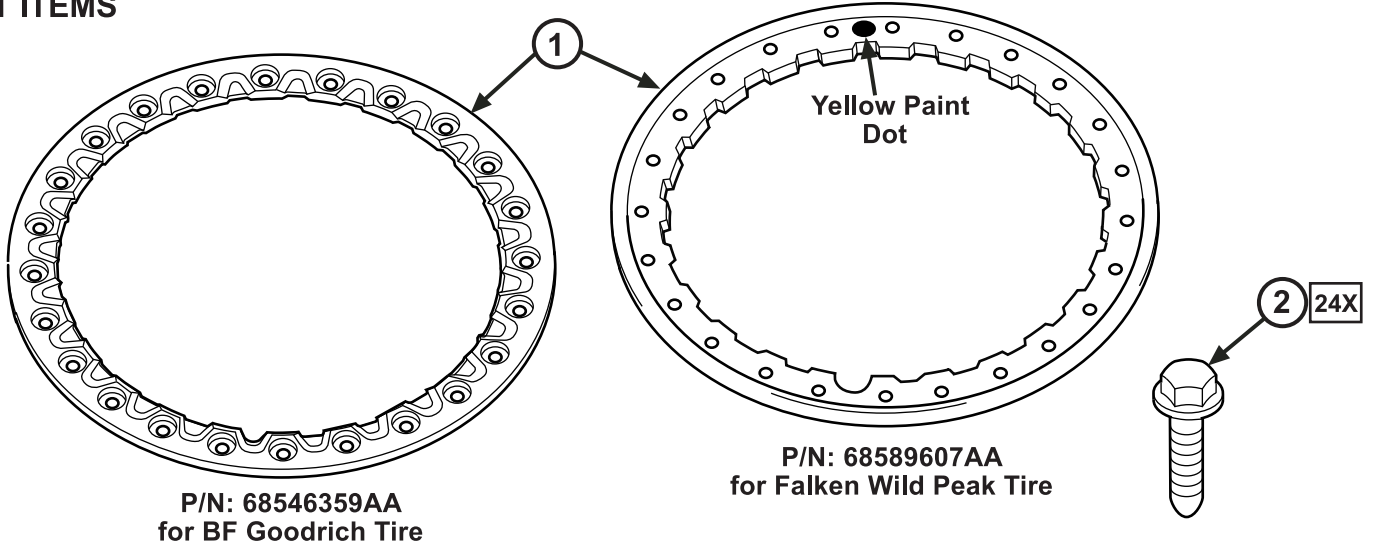

JEEP - FUNCTIONAL RING KIT (OFF-ROAD USE ONLY)

KIT ITEMS



TOOLS REQUIRED

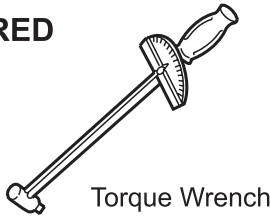

PARTS LIST

Callout	Description	Quantity	Part Number
1	Functional Bead Lock Ring	1	68546359AA / 68589607AA
2	Bolts	24	06512764AA

!!! READ, UNDERSTAND, & FOLLOW ALL INSTRUCTIONS CAREFULLY BEFORE INSTALLATION !!!

WARNING: Converting this wheel to true bead lock configuration is FOR OFF-ROAD USE ONLY. On-road use is NOT permitted.

NOTE: BFGoodrich KO2 LT285/70R17 OEM tire
Mopar recommends only using bead lock rings (Part number 77072586AA) designed for the Jeep application part number #77072585AA or 68508685AA. Any other combination could result in air pressure loss or tire failure.

NOTE: Falken Wild Peak KO2 LT285/70R17 OEM tire
Mopar recommends only using bead lock rings (Part number 77072599AA) designed for the Jeep application part number #77072585AA or 68508685AA. Any other combination could result in air pressure loss or tire failure.

OFF-ROAD USE ONLY PROCEDURAL STEPS

1. Remove wheel/tire from vehicle and deflate tire at valve stem.

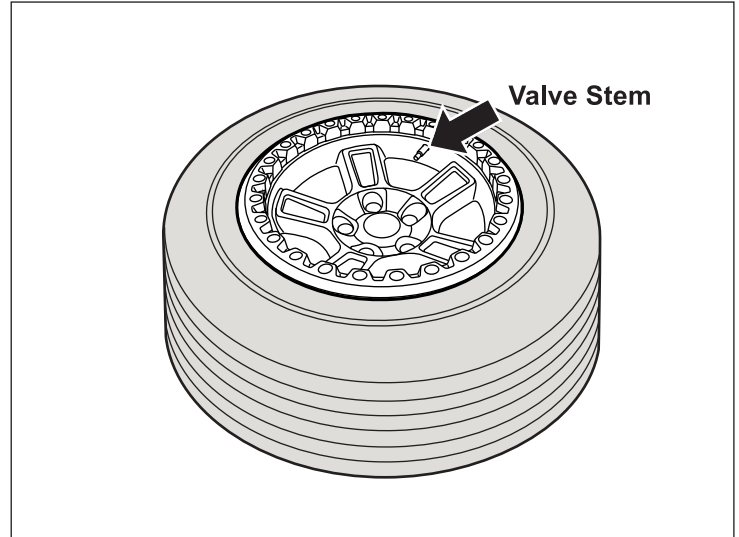
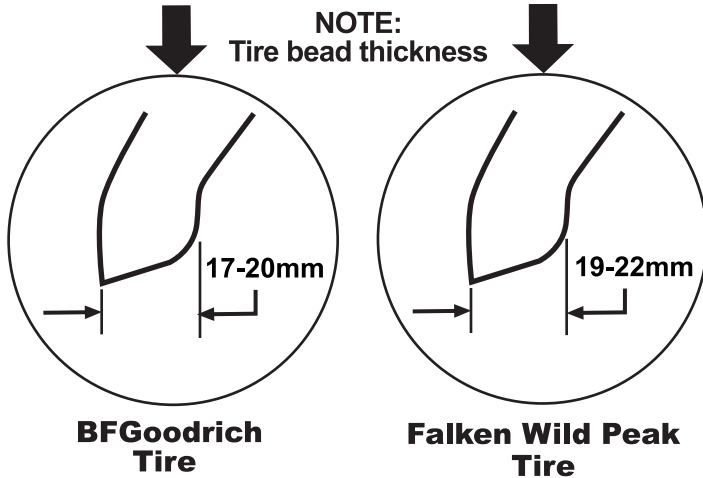

2. Break outer bead of tire from wheel and rest bead on outer wheel flange.

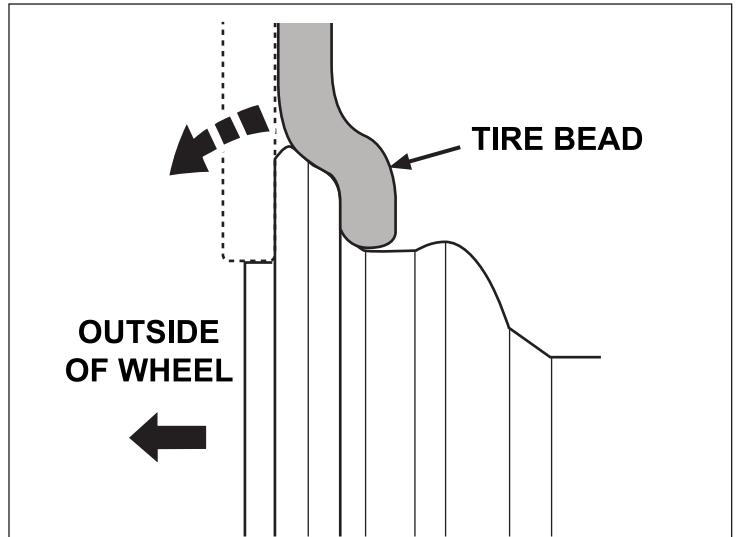

3. Position Bead Lock Ring (1) on top of outer bead and align bolt holes.

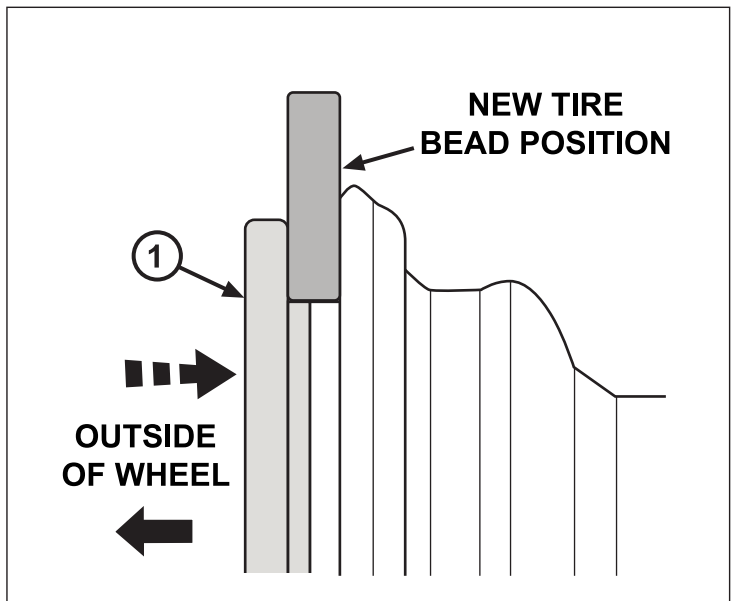

4. Hand tighten all bolts (2) into locking ring (1), ensure there are no gaps between the ring and wheel.

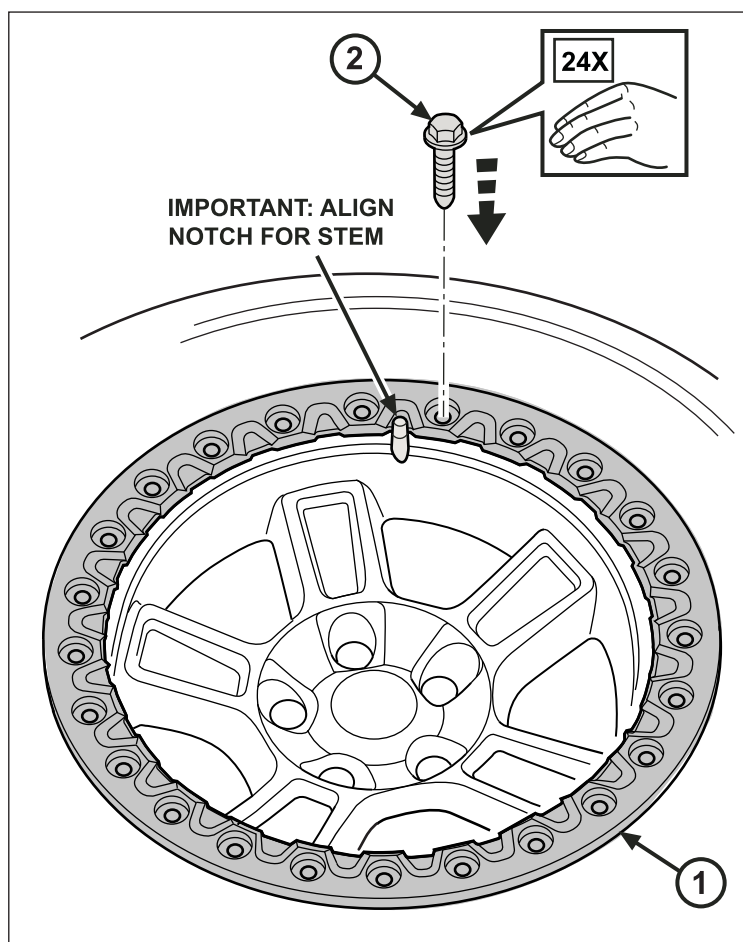

5. Torque bolts (2) in stages:

STAGE 1:

Torque all bolts (2) to 15 ft/lbs. (20 N.m), into locking ring (1). Ensure there are no gaps between the ring and wheel.

STAGE 2:

Torque all bolts to 26 ft/lbs. (35 N.m).

STAGE 3:

Torque all bolts to 37 ft/lbs. (50 N.m). Ensure there are no gaps between the ring and wheel.

NOTE: Check initial torque at 50 miles and every 500 miles. Ensure there are no gaps between the ring and wheel.

6. A: **Inflate** tire to recommended air pressure.
 B: **Balance** tire and wheel assembly.
 C: **Mount** tire to vehicle.

