

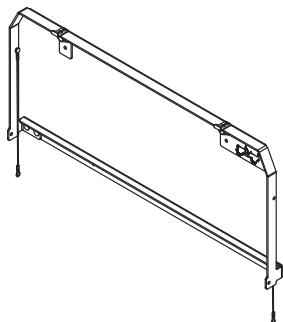

# TAILGATE TABLE JEEP WRANGLER

www.mopar.com

**A**  
x 1



**C**  
x 4

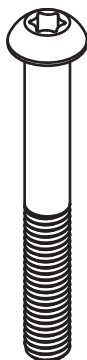

**D**  
x 1



**E**  
x 3

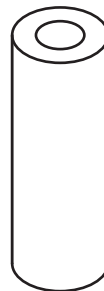

**F**  
x 2

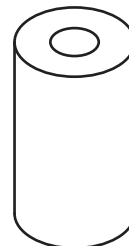

**G**  
x 2



**B**  
x 1

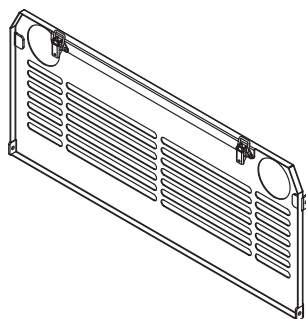

**H**  
x 4



**I**  
x 2

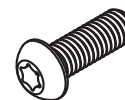

**J**  
x 2

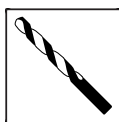

13mm

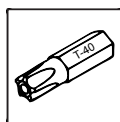
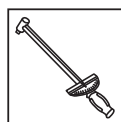

T-40

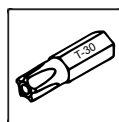

T-30

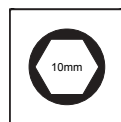

10 mm

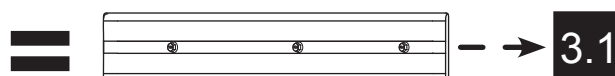
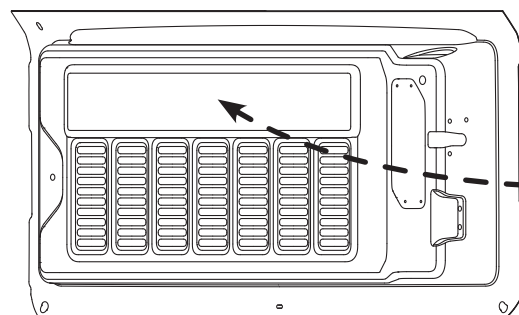
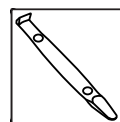

1

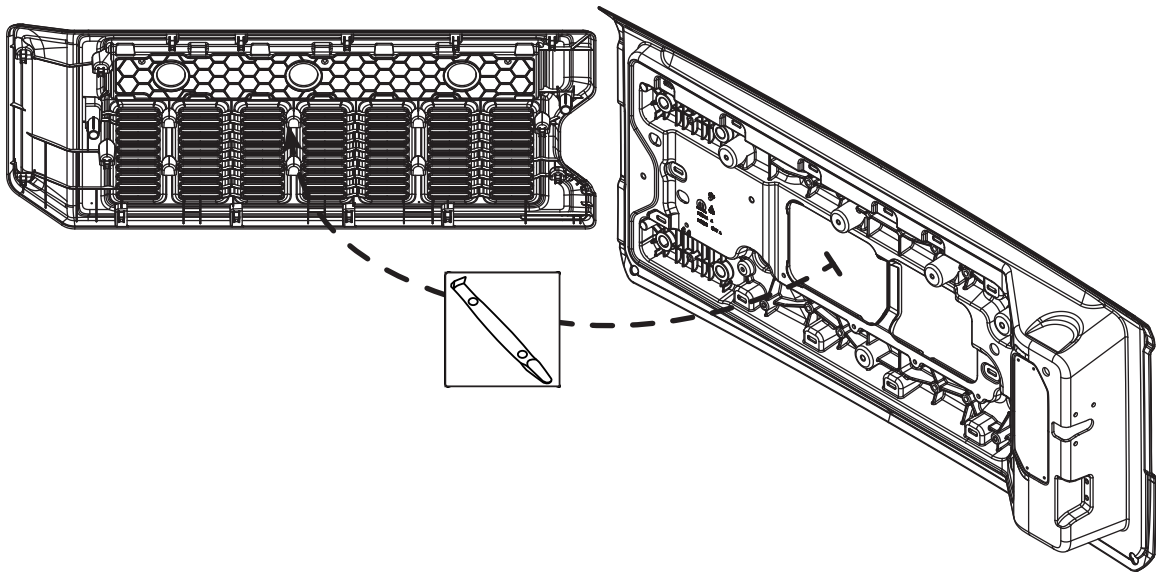

2.1

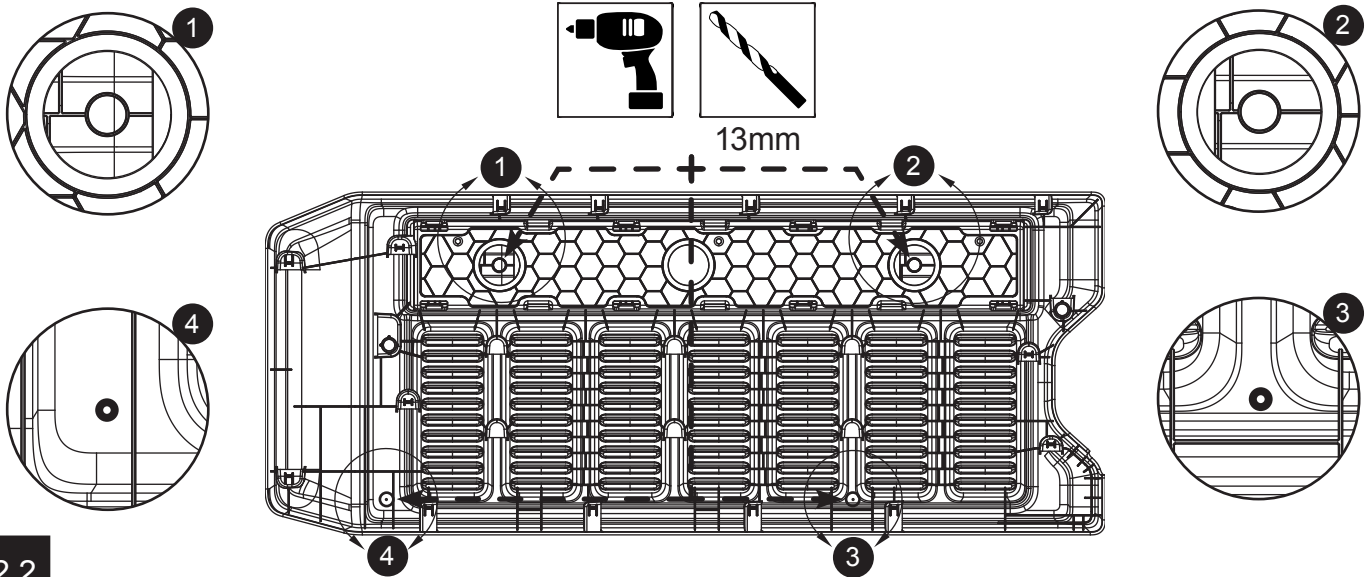

2.2

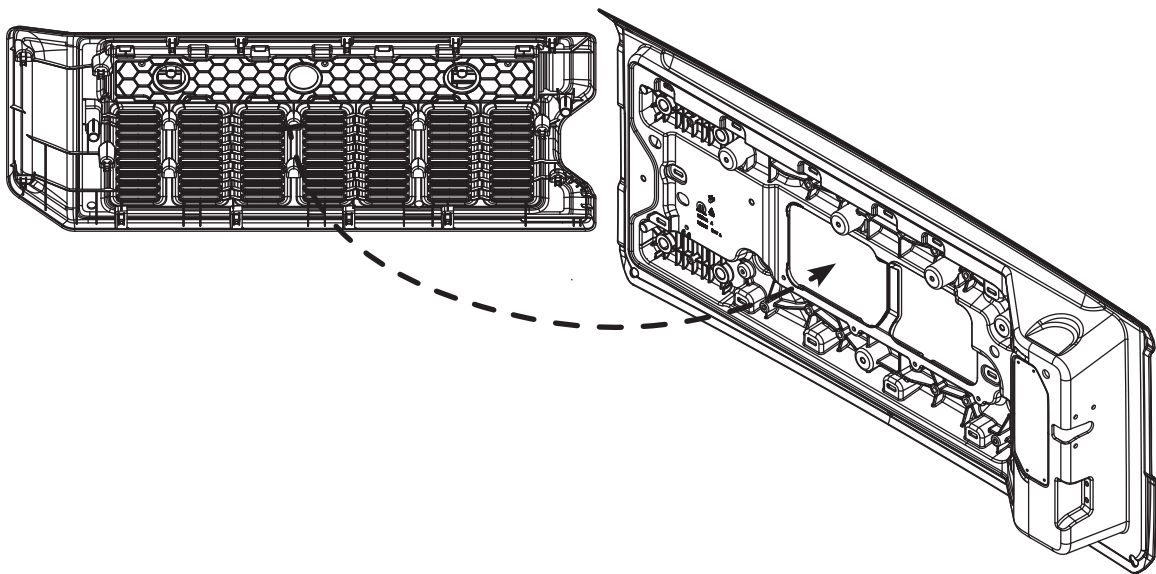

2.3

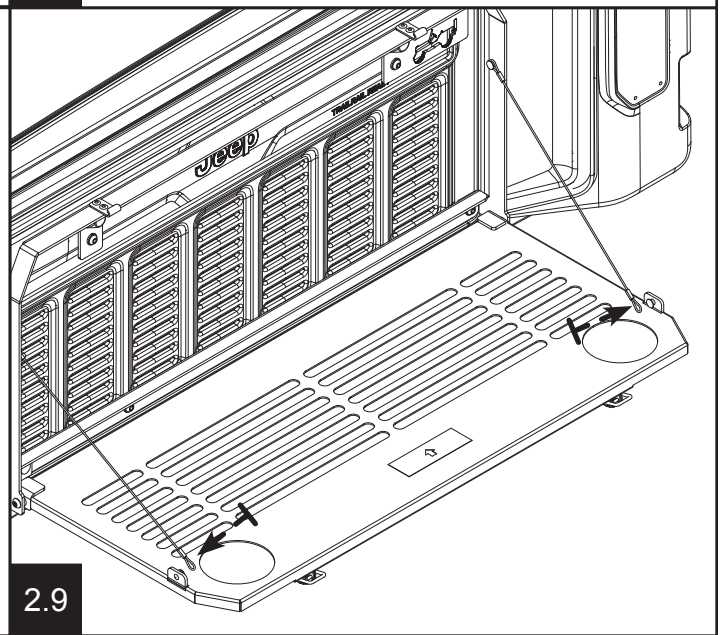
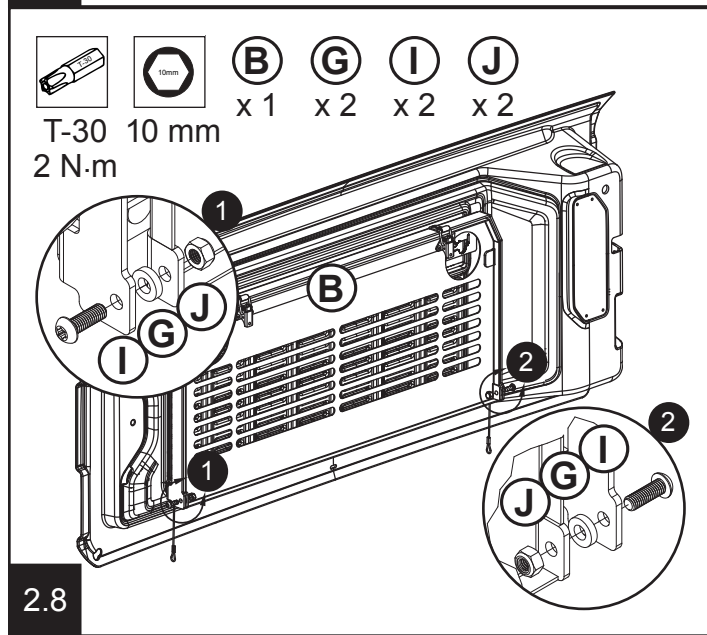
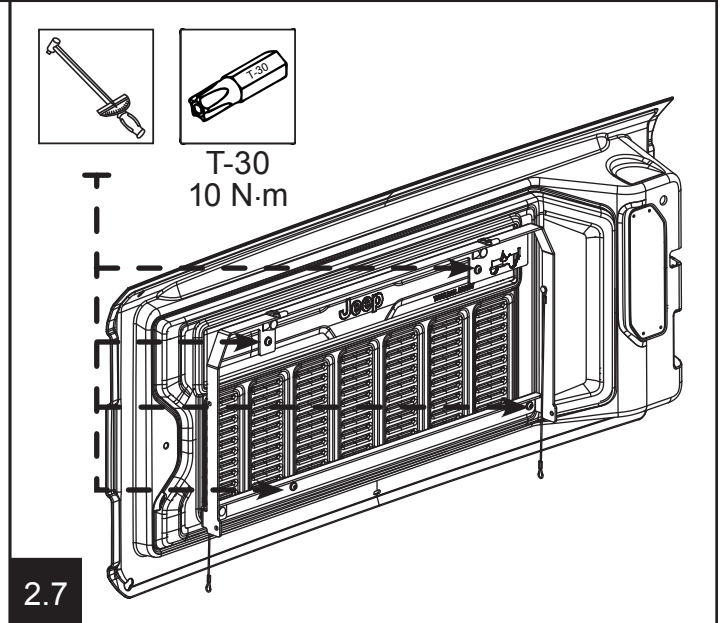
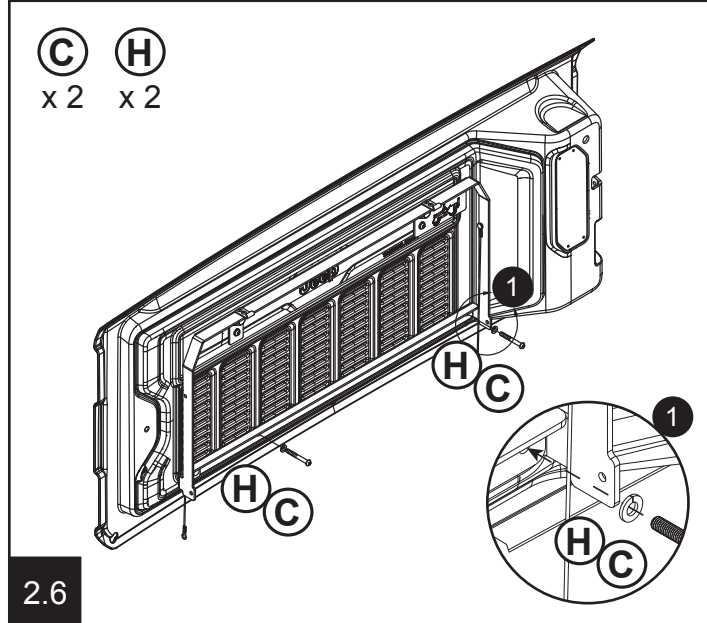
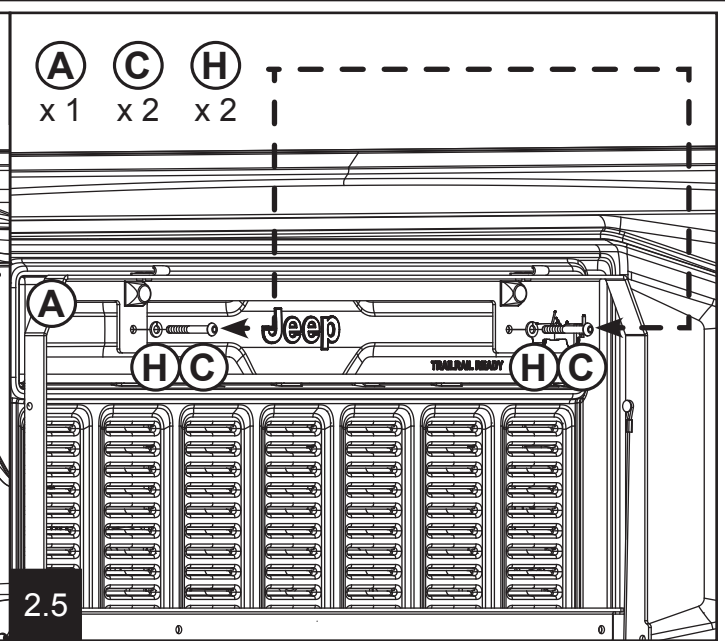
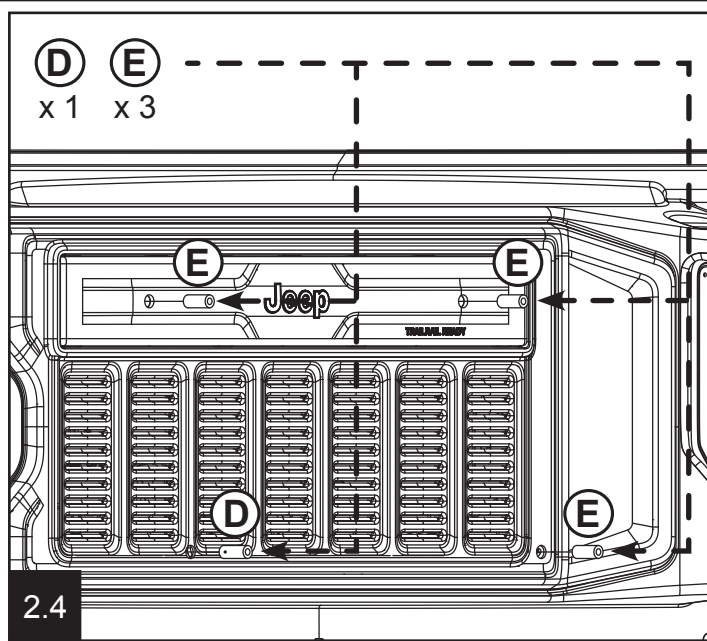

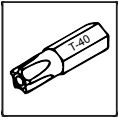

T-40

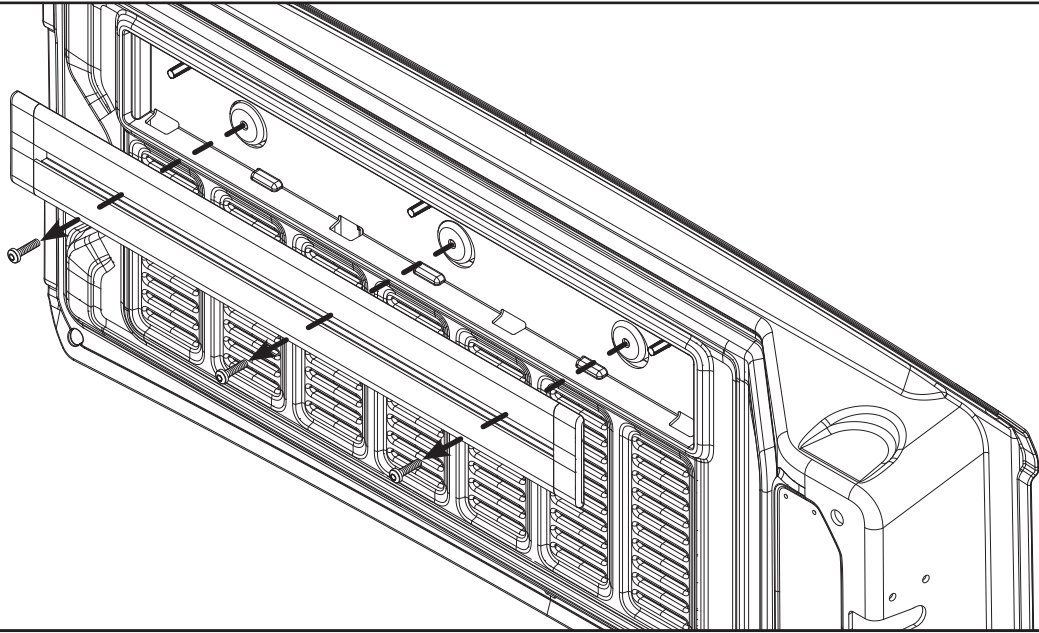

3.1

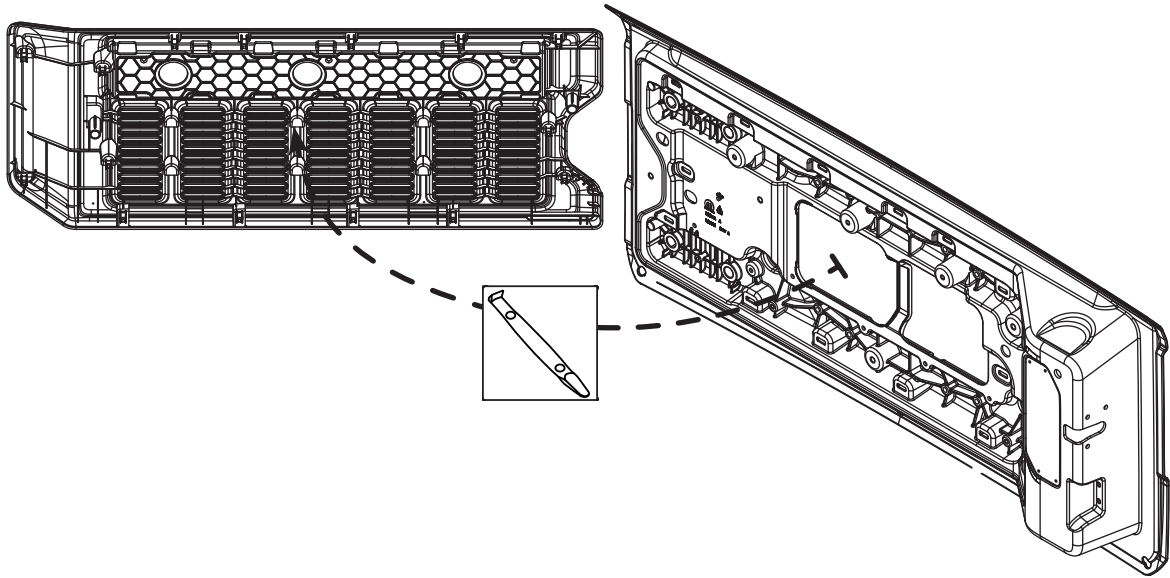

3.2

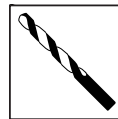
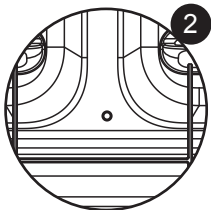
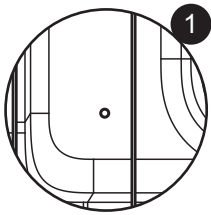

13mm

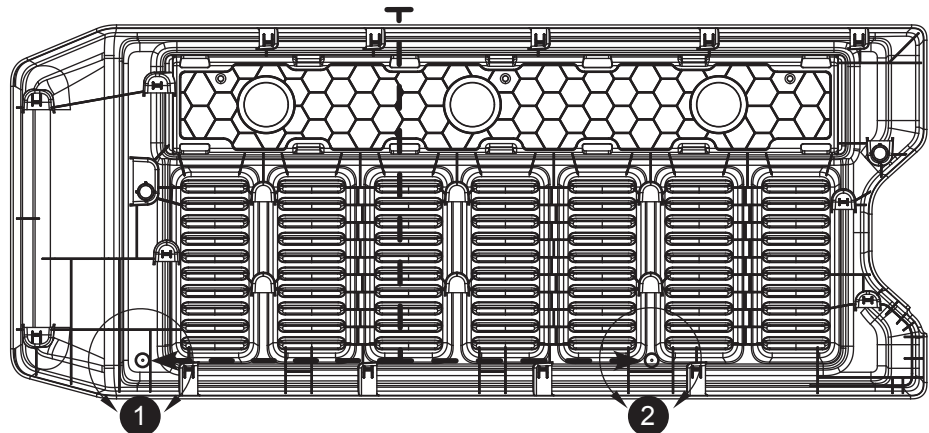

3.3



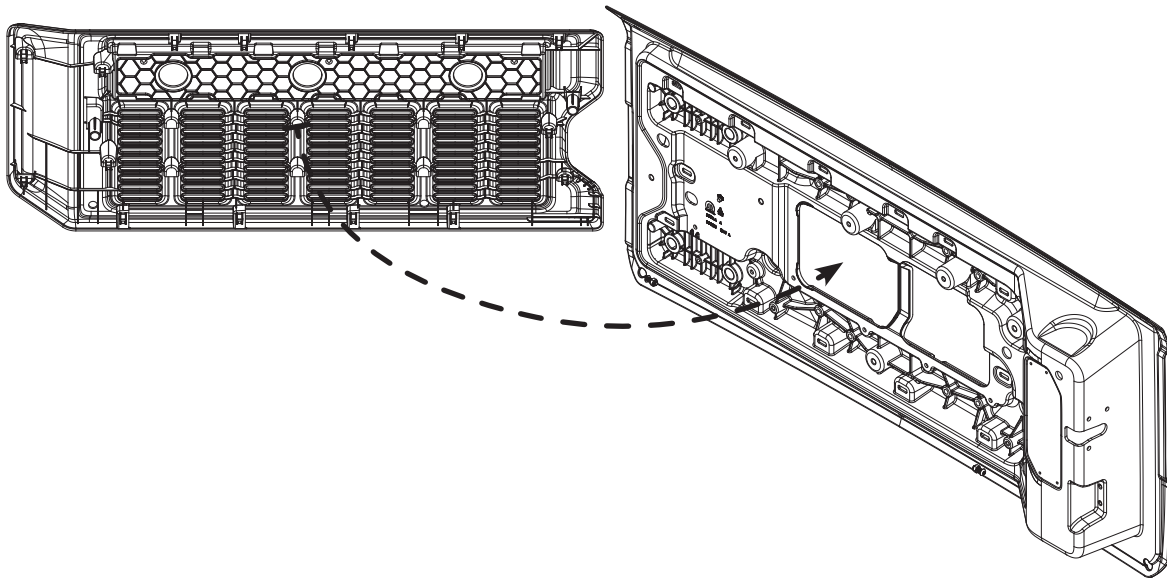

3.4



T-40  
8 N·m

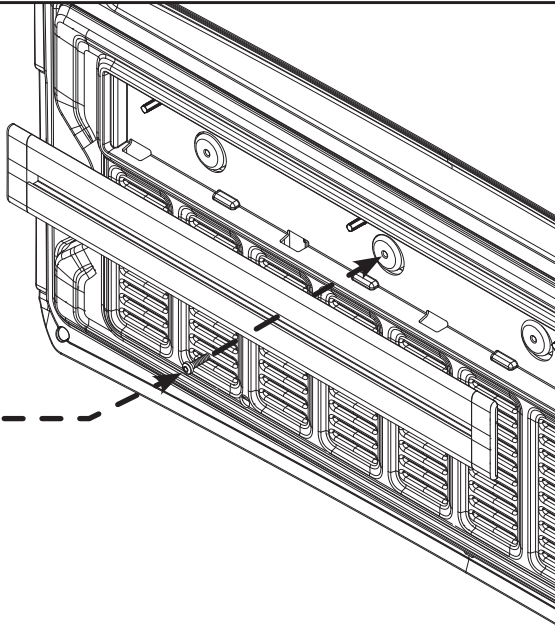

3.5

A C F H  
 x1 x2 x2 x2

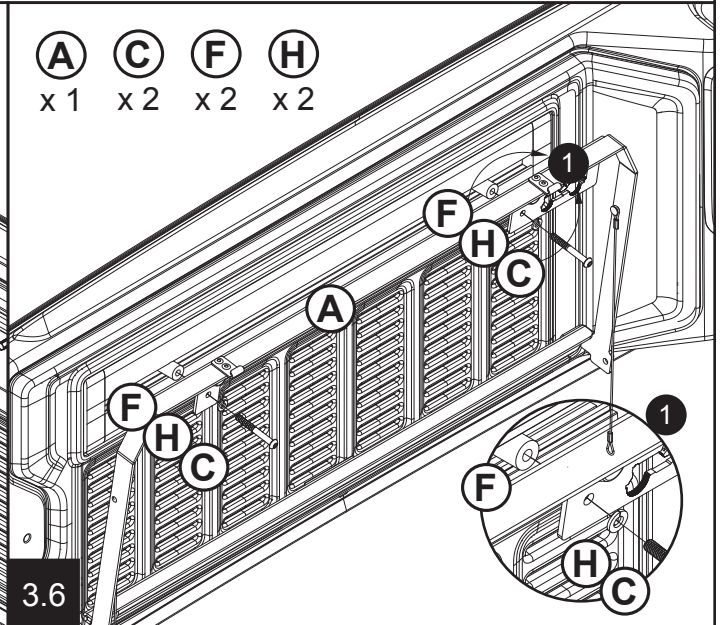

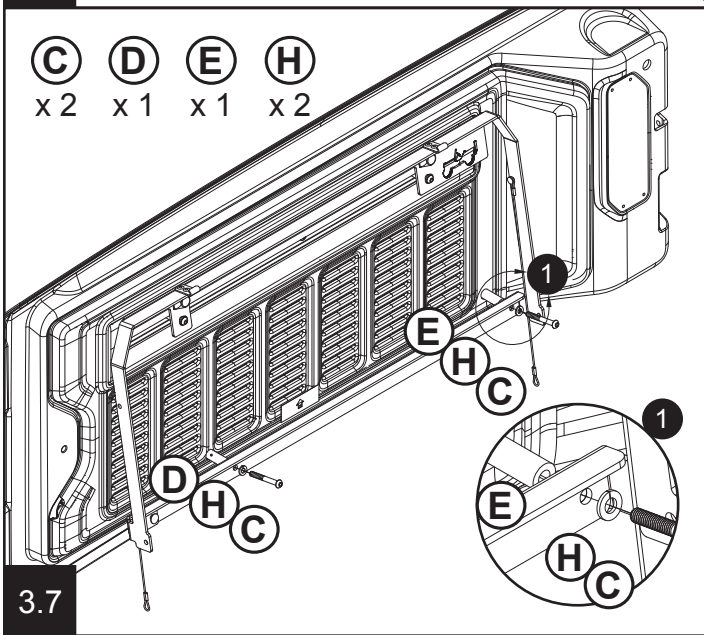

3.6

C D E H  
 x2 x1 x1 x2



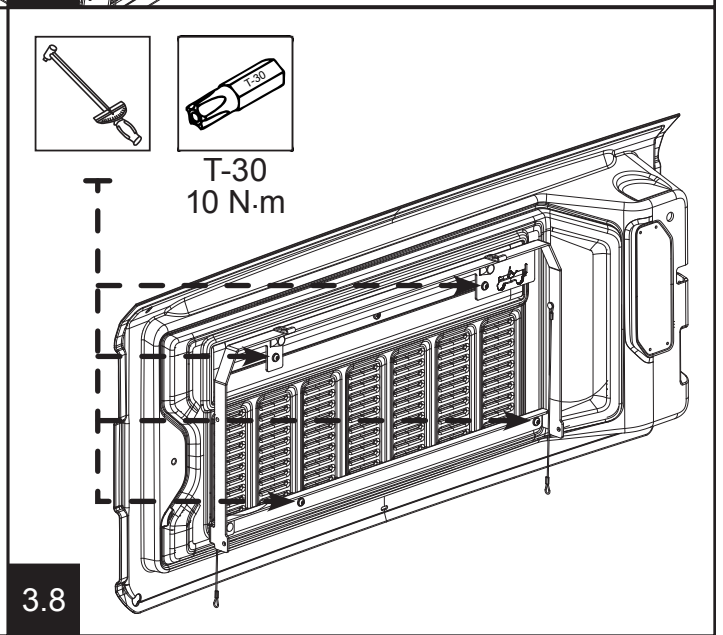

3.7

  
 T-30  
 10 N·m



3.8

-  T-30
  -  10 mm
  - B** x 1
  - G** x 2
  - I** x 2
  - J** x 2
- 2 N·m

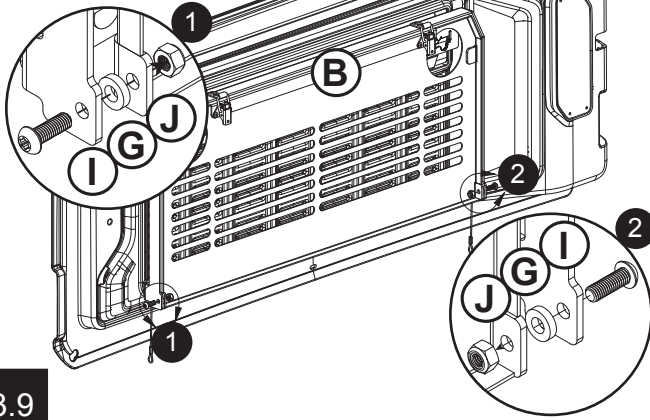

3.9

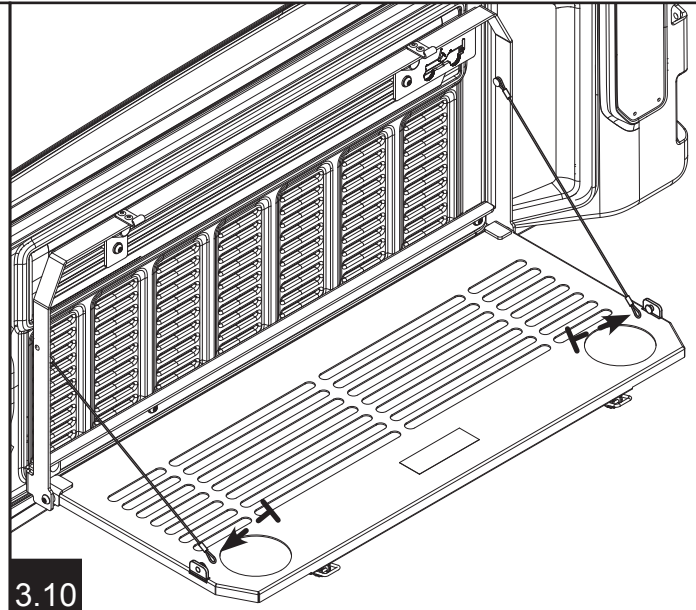

3.10

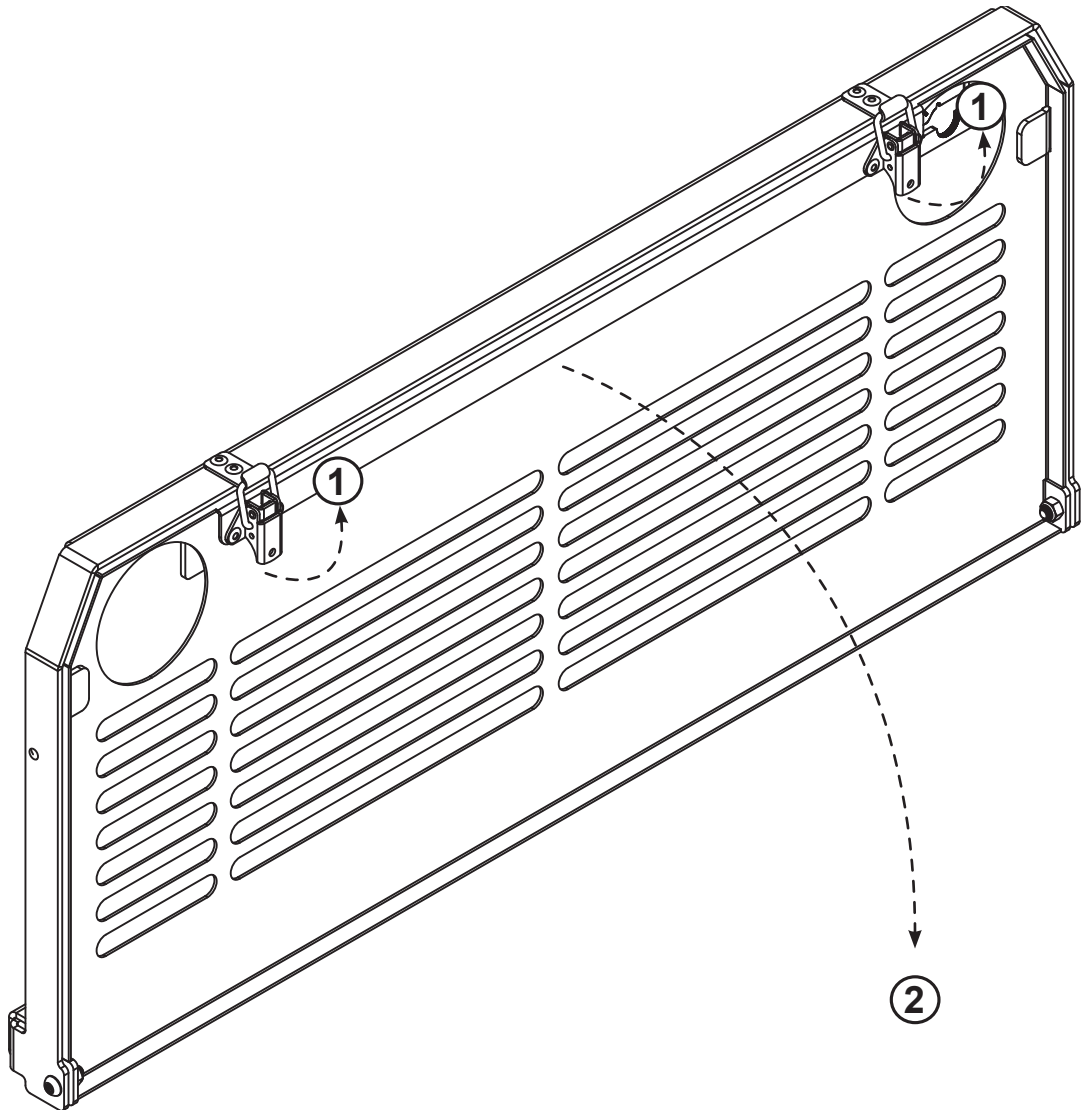

4