



Ram 3500

5th Wheel Prep Kit

MOPAR®

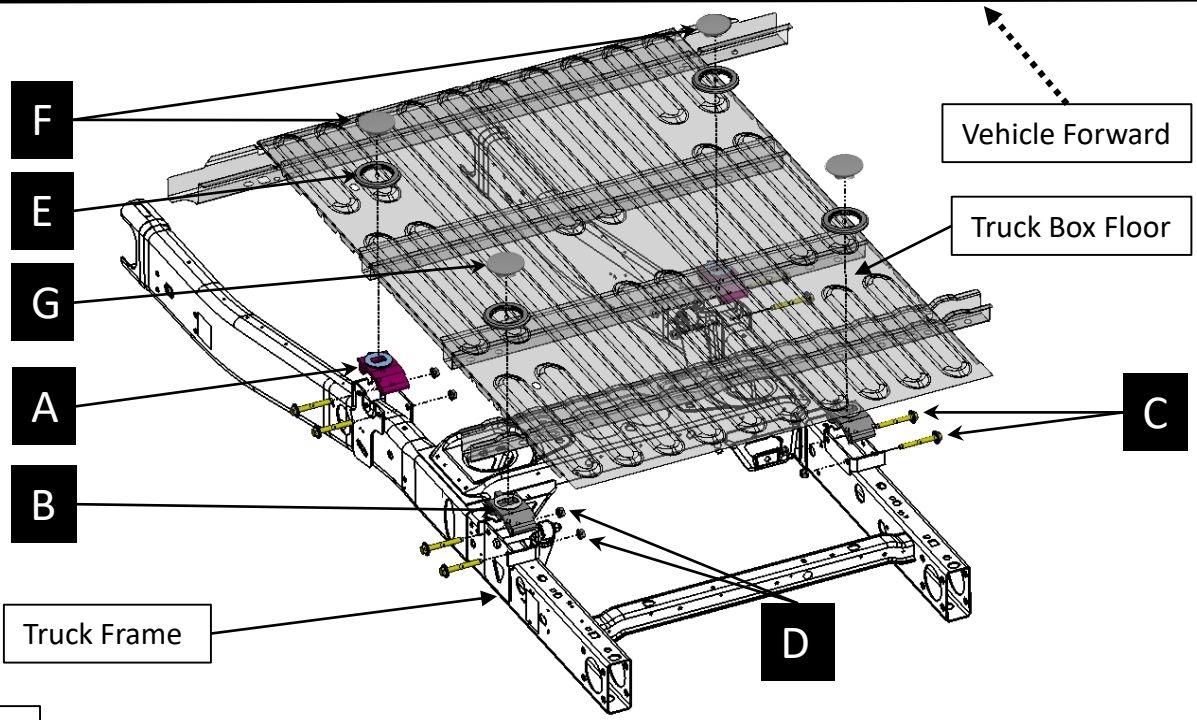

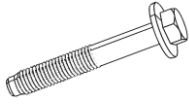





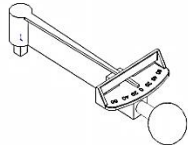

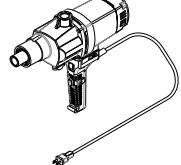



Figure 1

<p>Front 5th Wheel Mount</p>  <p>A 2x 68349561AA</p>	<p>Rear 5th Wheel Mount</p>  <p>B 2x 68349563AA</p>	<p>Bolt M14-1.5x120mm</p>  <p>C 8x 06105118AA</p>	<p>Flange Nut M14-1.5</p>  <p>D 8x 06104712AA</p>
<p>Trim Ring – 5th wheel mount</p>  <p>E 4x 124031</p>	<p>Trim Cover – 5th wheel mount - front</p>  <p>F 2x 124032</p>	<p>Trim Cover – 5th wheel mount - rear</p>  <p>G 2x 124033</p>	

Tools Required

<p>Safety Eyewear</p> 	<p>Torque wrench</p> 	<p>21mm socket, extension, Ratchet</p> 	<p>21mm Wrench</p> 	<p>Drill motor</p> 	<p>3 3/4" Hole saw</p> 
--	--	--	--	---	--

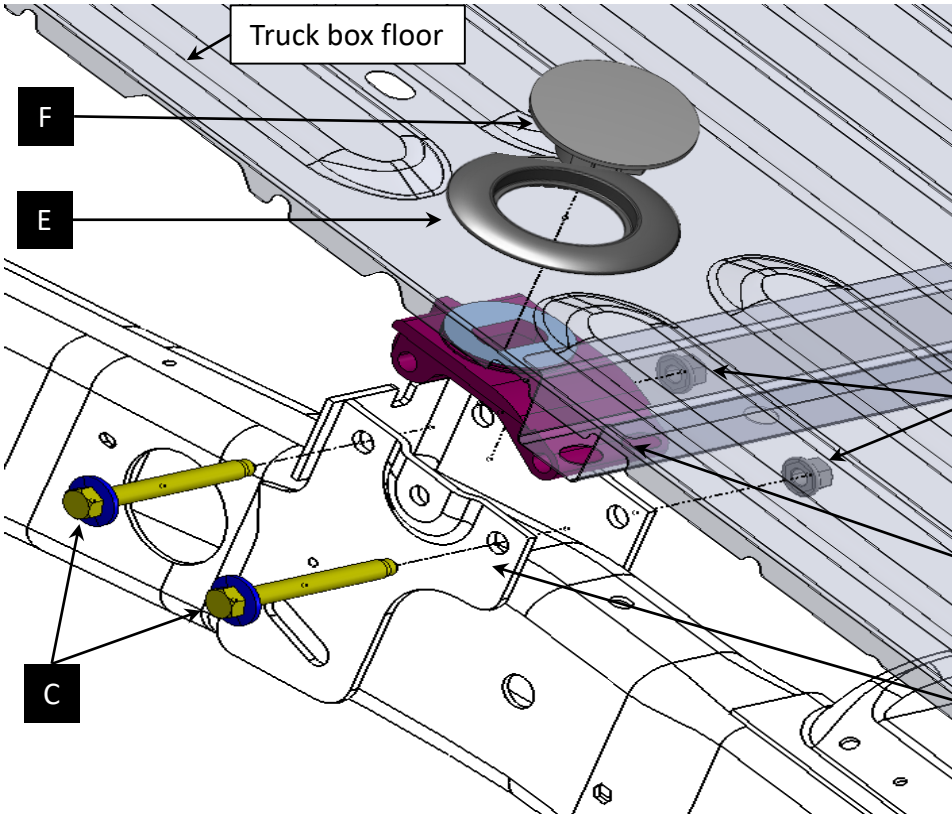

Figure 2
Front 5th wheel mount

Note: Assembly typical both sides

- D** [Image of nut]
- A** 5th wheel casting 'boss'
- Truck frame bracket

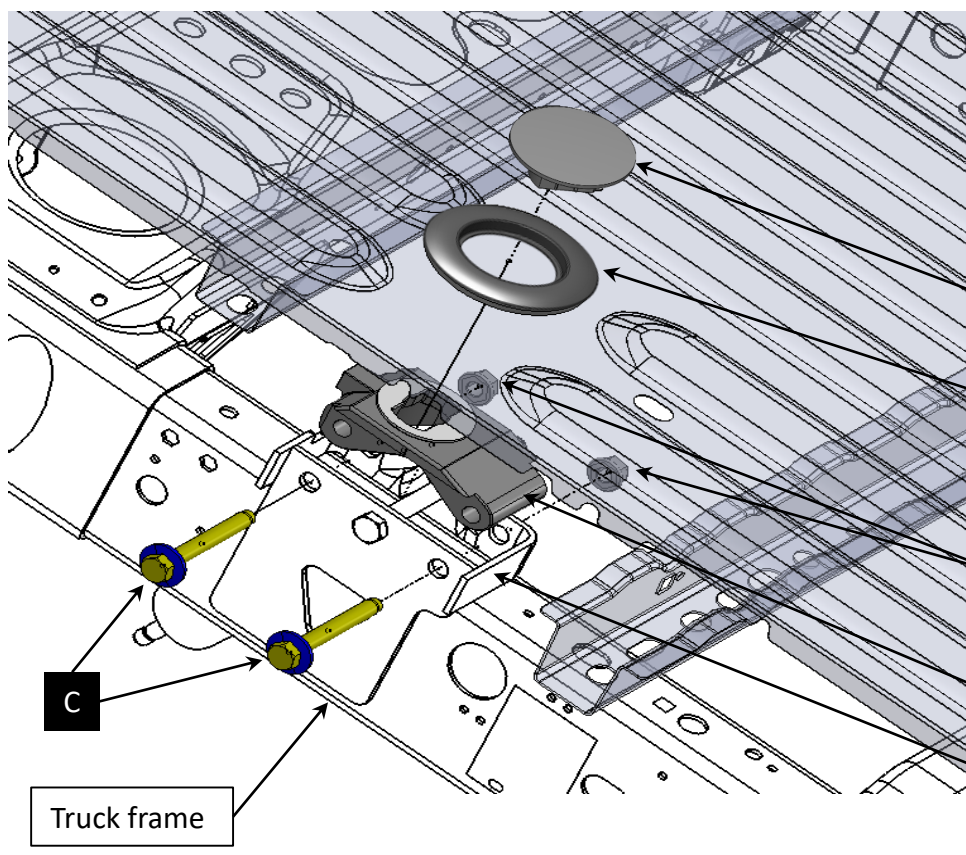
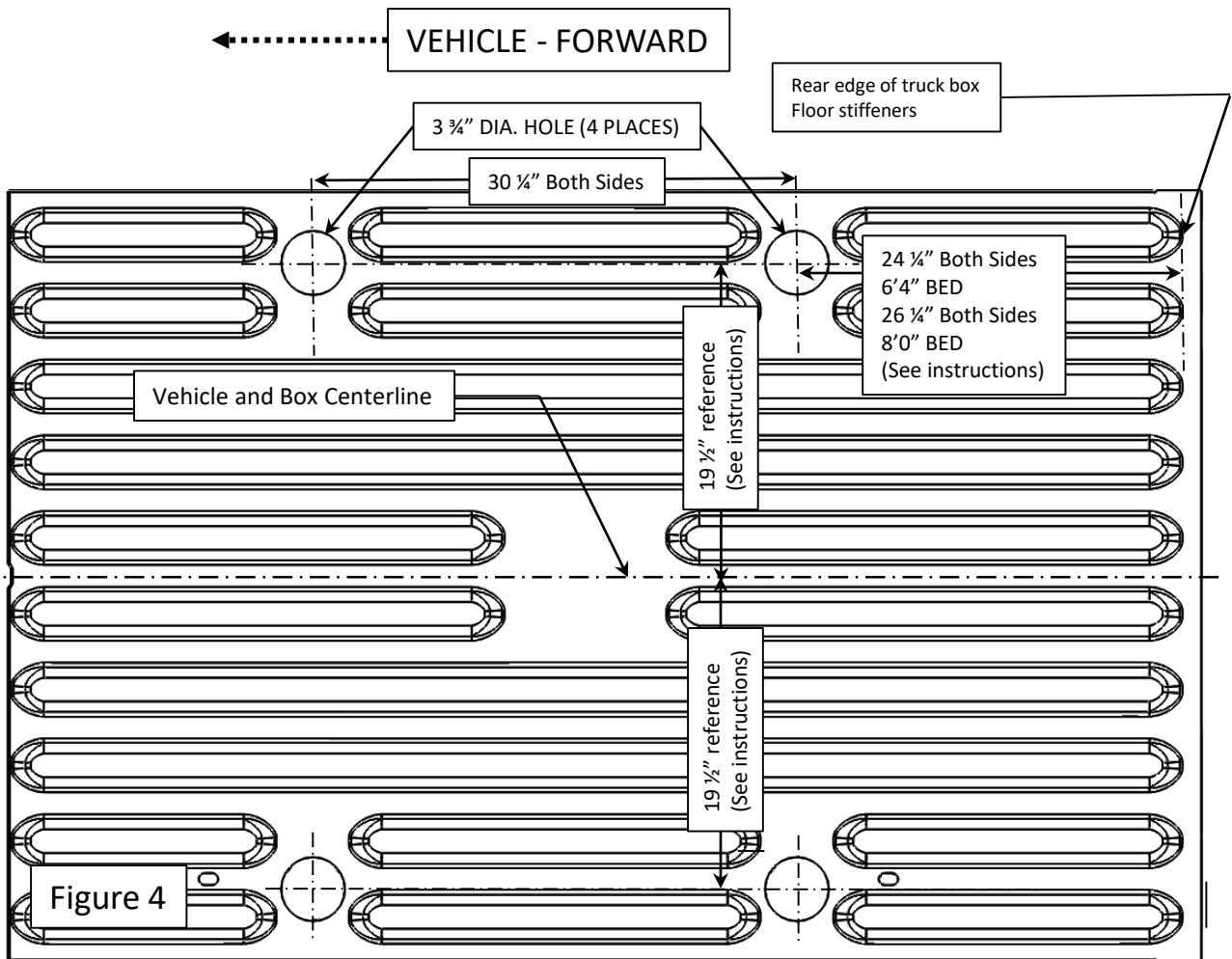

Figure 3
Rear 5th wheel mount

Note: Assembly typical both sides

- G** [Image of spacer tube]
- E** [Image of washer]
- D** [Image of nut]
- B** 5th wheel casting 'boss'
- Truck frame bracket

Note: check hitch frequently, making sure all fasteners and ball are properly tightened. A hitch or ball which has been damaged should be removed and replaced. Observe safety precautions when working beneath a vehicle and wear eye protection. Do not cut access or attachment holes with a torch.



Installation Instructions:

Step A - 5th wheel mount installation

- 1) Review and familiarize yourself with all components (Fig. 1). Verify all components are supplied.
- 2) Safely block vehicle and work in a safe manner.
- 3) Remove spare tire.
- 4) Working from one side of the vehicle, remove all the truck box bolts (3 bolts on the 6'4" box, 4 bolts on the 8 ft box) holding truck box to vehicle frame (PASSENGER SIDE ONLY). Loosen but leave in place the bolts holding the driver's side of the truck box. This is done to maintain box alignment. Lift and block side of truck box approx. 6". Check to assure no wires, fuel filler or other items attached to the box are stressed. Check also to assure there is clearance between the front of the box and rear of the cab. Finally check for clearance between the rear of the truck box and rear bumper.
- 5) Install part 'A' 5th wheel receiver front in frame bracket as shown in (Fig. 2), **NOTE ORIENTATION**.
- 6) Install part 'B' 5th wheel receiver rear in frame bracket as shown in (Fig. 3), **NOTE ORIENTATION**.
- 7) Fasten casting (both sides) through the frame bracket carrier using (2) M14-1.5x120mm bolts and (2) M14-1.5 nuts (parts 'C' & 'D'). (Fig. 2)
- 8) At this step, both 5th wheel receivers on one side of the vehicle should be in place with fasteners loosely installed
- 9) Torque bolts holding the tiedown receiver to 136 Lb.-Ft. (185 N*m)
- 10) Lower the passenger side truck box onto the frame and loosely install the bolts removed in step 4.
- 11) Remove the truck box hold down bolts from the driver's side of the truck box. Lift and block the driver's side of truck box approx. 6"
- 12) Repeat steps 5, 6, 7 & 9 on the driver's side of vehicle
- 13) Lower the truck bed onto the frame. Install and torque truck bed hold down bolts to specification (See RAM service manual for torque specs.)

Note: check hitch frequently, making sure all fasteners and ball are properly tightened. A hitch or ball which has been damaged should be removed and replaced. Observe safety precautions when working beneath a vehicle and wear eye protection. Do not cut access or attachment holes with a torch.

Step - B Drill Holes in truck box floor

When installing the 82215837 5th Wheel prep kit, 4 holes must be drilled in the bed of the truck. It is critical that these directions are followed.

Rear 5th wheel mounts :

- 14) From inside the box, mark the centerline of the box. Use chalk or some other temporary marking method. For 6'4" beds, measure and mark a spot 24 ¼" (616mm) forward of the rearmost edge of the truck box floor stiffeners. For 8'0" truck beds, measure 26 ¼" (667mm) forward of the rearmost edge of the truck box floor stiffeners. Strike an additional line 90 degrees to the spot marked. (See Fig. 4)
- 15) Measure outward in both directions, along the line you marked in the previous step, 19 ½" (495mm). You should have two targets marked (See Fig. 4)
- 16) Drill ¼" pilot hole two (rh & lh) places where you marked the center of the rear 5th wheel mounts.

Front 5th wheel mounts:

- 17) From inside the box, using the previously marked centerline of the box, mark a spot 30 ¼" (768mm) forward of the line used for the rear 5th wheel mounts in ¼" pilot holes drilled. Strike an additional line 90' (degrees) to the spot marked.(See Fig.4)
- 18) Measure outward in both directions, along the line you marked in the previous step, 19 ½" (495mm). You should have four targets marked (See Fig. 4)
- 19) Drill ¼" pilot hole two (rh & lh) places where you marked the center of the front 5th wheel mounts.
- 20) You should now have 4, ¼" holes drilled in the truck box floor.

CHECK YOUR WORK! From the top of the bed, verify that the ¼" holes match the dimensions and appearance of Fig. 4. THIS IS YOUR LAST CHANCE to make adjustments before drilling the large 3 ¾" holes in your truck bed.

- 21) Drill four (2 lh & 2 rh) 3 ¾" holes using a hole saw. Use the ¼" pilot hole as a guide (Fig.4)

CHECK YOUR WORK! From the top of the bed, verify that the holes in the bed align with 5th wheel mount receivers. Some slight adjustment of the truck box is possible. If there is a slight misalignment, install the appropriate trim ring and mark the outside perimeter of the ring on the truck box floor. Remove the trim ring. It is permissible to grind the opening if needed to within 1/8" of the marked outside trim ring perimeter.

- 22) Use rust inhibitor or equivalent primer paint on raw edges of drilled holes. Paint as desired to match truck color.

Step - C Trim rings and covers installation

- 23) Trim rings– Press trim rings (items E) into holes on floor. Trim rings should snugly fit around castings with the lip of the trim ring tight to the floor. It may be necessary to use a flat bladed tool to assist in fitting trim rings around the castings. Use flat bladed plastic trim tool, tongue depressor, plastic serving knife or similar item. Use of a sharp tool or flat blade screwdriver may damage the trim ring.
- 24) Trim covers - Press trim covers (parts F & G) into trim ring holes on floor. Trim covers should snugly fit inside the trim rings. **NOTE: Trim covers are not the same:** There are (2) covers for the front 5th wheel mount and (2) covers for the rear 5th wheel mount.
- 25) **Re-Assemble your truck – Check all fasteners for proper torque,** re-install spare tire, re-connect any wires, hoses or anything else that may have been loosened or removed. Check to assure all wires, hoses and other components have not been pinched between box and frame.

Tighten all (8) M14 bolts with torque wrench to 136 Lb.-Ft. (185 N*m)

Note: check hitch frequently, making sure all fasteners and ball are properly tightened. A hitch or ball which has been damaged should be removed and replaced. Observe safety precautions when working beneath a vehicle and wear eye protection. Do not cut access or attachment holes with a torch.